

Children Vehicle

OPERATION MANUAL STRONG QUAD SERIES



Please read this manual carefully before operation
The children must operate the vehicle under guidance

TABLE OF CONTENTS

Warnings and Cautions.....	2
Parts.....	3
Parts Picture.....	5
Battery Charging.....	6
Assembly.....	7
Battery Installation.....	13
Battery Care and Disposal.....	14
Safe Driving Rules.....	15
Vehicle Operation.....	16
Vehicle Care.....	17
Problems and Solutions Guide.....	18

CAUTION

ELECTRICAL HAZARD



- . Battery can fall out and injure a child if vehicle tips over. Always use battery retainer.
- . **PREVENT FIRE**
 - Never modify the electrical system. Alterations could cause a fire resulting in serious injury and could also ruin the electrical system.
 - Use of the wrong type battery or charger could cause a fire or explosion resulting in serious injury.
 - Use of components in products other than vehicles could cause overheating, fire or explosion.
- . The battery must be handled by adults only. The battery is heavy and contains sulfuric acid (electrolyte). Dropping the battery could result in serious injury.
- . Never allow children to charge the battery. Battery charging must be done by adults only. A child could be injured by the electricity involved in charging the battery.
- . Examine the battery, charger and their connectors for excessive wear or damage each time you charge the battery. If damage or excessive wear is detected, do not use the charger or the battery until you have replaced the worn or damaged part
- . **HOT motors. Handle carefully.**

RIDING HAZARD



- Prevent Injuries and Deaths
- . Direct Adult Supervision Required.
- . Never Ride at Night.
- . Keep Children Within Safe Riding Areas.
- These areas must be:
 - away from swimming pools and other bodies of water to prevent drownings
 - generally level to prevent tipovers
 - away from steps, steep inclines, cars, roads and alleys.
- . **Riding Rules**
 - Make sure children know and follow these rules for safe driving and riding.
 - Always sit on the seat.
 - Always wear shoes.
 - Only 1 (one) rider at a time.



- . In the unassembled state, this package contains small parts. Adult assembly is required.
- . Use the charger in dry locations only.

CAUTION

PARTS

- . Please identify all parts before assembly and save all packaging material until assembly is complete to ensure that no parts are discarded.
- . Some parts were placed under the seat for shipment. Press the tab under the back of the the seat and lift to access the battery compartment.
- . Metal parts have been coated with a lubricant to protect them during shipment. Wipe all metal parts with a paper towel to remove any excess lubricant.

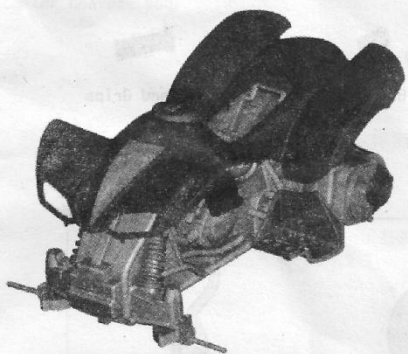

Vehicle



Handlebar



Seat



Steering Column Cap



plate



2 Rear Wheel Drivers



2 Left Wheels
(Marked with an L)



2 Right Wheels
(Marked with an R)



Front Clip



Brush Guard

PARTS



Rear Axle



12 Volt Battery



12 Volt Charger



4 Hubcaps



4 Wheel Covers



4 Bushings



2 Hand Grips

Part Not Shown: Label Sheet

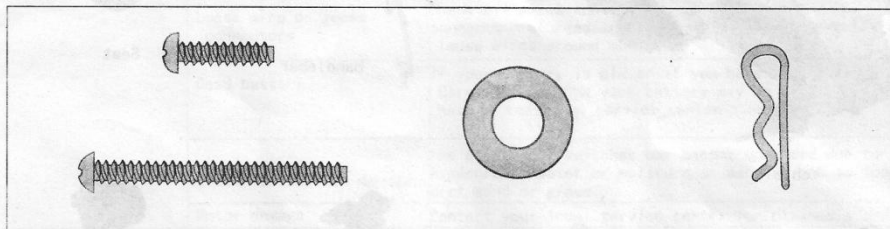

PARTS PICTURE

Note: Some parts shown are assembled on both sides of the vehicle.

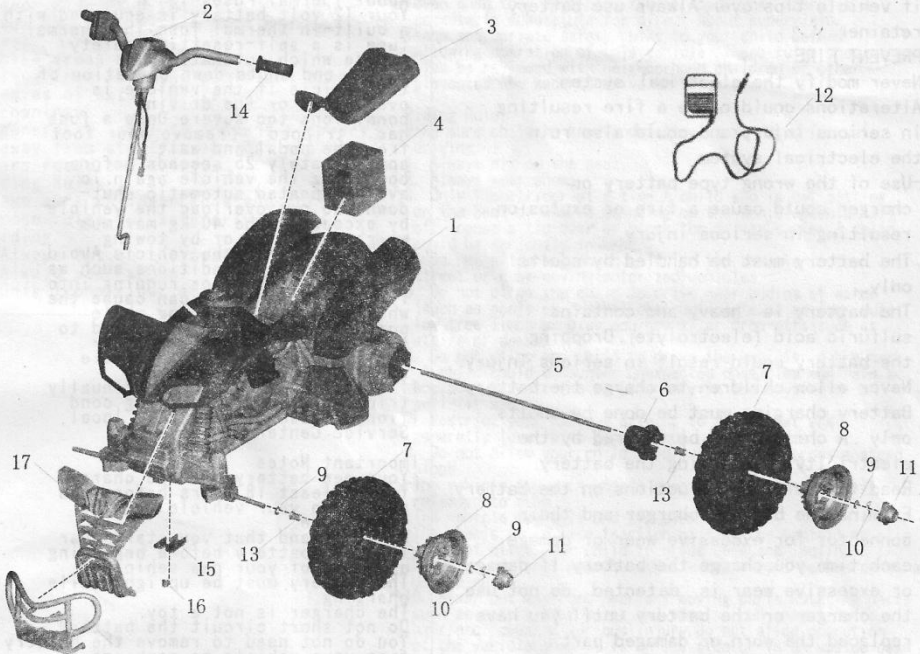

- | | | |
|------------------------|-----------------------------|-------------------------|
| 1. Vehicle | 7. Wheel-4 | 13. Bushing-4 |
| 2. Handlebar | 8. Wheel Cover-4 | 14. Hand Grip-2 |
| 3. Seat | 9. Washer-6 | 15. Plate |
| 4. 12 Volt Battery | 10. Cotter Pin-4 | 16. Steering Column Cap |
| 5. Rear Axle | 11. Hubcap-4 | 17. Front Clip |
| 6. Rear Wheel Driver-2 | 12. 12 Volt Battery Charger | 18. Brush Guard |

BATTERY CHARGING

ELECTRICAL HAZARD



WARNING

Battery can fall out and injure a child if vehicle tips over. Always use battery retainer.

PREVENT FIRE

- Never modify the electrical system. Alterations could cause a fire resulting in serious injury and could also ruin the electrical system.
- Use of the wrong type battery or charger could cause a fire or explosion resulting in serious injury.
- . The battery must be handled by adults only.
- The battery is heavy and contains sulfuric acid (electrolyte). Dropping the battery could result in serious injury.
- . Never allow children to charge the battery. Battery charging must be done by adults only. A child could be injured by the electricity in charging the battery.
- . Read the safety instructions on the battery.
- . Examine the battery, charger and their connector for excessive wear or damage each time you charge the battery. If damage or excessive wear is detected, do not use the charger or the battery until you have replaced the worn or damaged part.



WARNING

Use the charger in dry locations only

About Thermal Fuses

Your 12 volt battery is equipped with a built-in thermal fuse. The thermal fuse is a self-resetting safety device which automatically tips and shuts down operation of the vehicle if the vehicle is overloaded or the driving conditions too severe. Once a fuse has tripped, remove your foot from the pedal and wait approximately 25 seconds before operating the vehicle again. To avoid repeated automatic shut-downs, do not overload the vehicle by exceeding the 40 kg maximum weight capacity or by towing anything behind the vehicle. Avoid severe driving conditions, such as driving up slopes or running into fixed objects, which can cause the wheels to stop spinning while power is still being supplied to the motors and make sure your child stops the vehicle before switching direction.

If a fuse in a battery continually trips under normal driving conditions, please contact your local Service Center.

Important Notes

- . Your new battery must be charged for at least 18 hours before you use it in your vehicle for the first time.
- . We recommend that you start charging your battery before beginning assembly of your new vehicle.
- . The battery must be upright while charging.
- . The charger is not a toy.
- . Do not short circuit the battery.
- . You do not need to remove the battery from your vehicle to recharge it.
- . Before charging the battery, examine the battery case for cracks and other damage which may cause sulfuric acid (electrolyte) to leak during the charging process. If damage is detected, do not charge the battery or use it in your vehicle. Battery acid is very corrosive and can cause severe damage to surfaces it contacts.
- . Do not charge the battery on a surface (such as a kitchen counter top) which could be damaged by the acid contained inside the battery.
- . Take precautions to protect the surface on which you charge your battery.
- . Use only a 12 volt charger with 12V connector to charge your 12 volt battery.
- . Adults Note: Regularly examine the charger for damage to the cord, plug, housing or other parts that may result in the risk of fire, electric shock or injury. In the event of any damage, do not use the charger until they has been properly repaired.
- . If your battery is old and will not accept a charge, do not leave it in the vehicle. Always remove a dead battery from the vehicle.

ASSEMBLY



WARNING

Children can be harmed by small parts, sharp edges and sharp points in the vehicles unassembled state, or by electrical items. Care should be taken in unpacking and assembly parts, including the battery, or help in assembly of the vehicle.

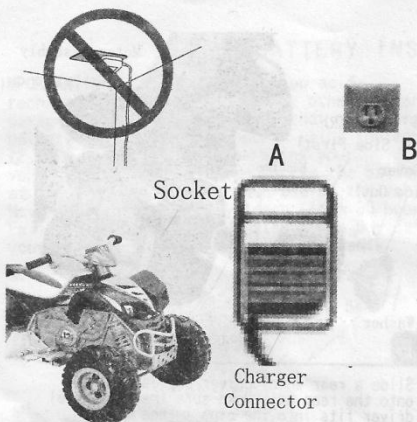

- Plug the charger connector into the socket A.
- Plug the charger into a standard wall outlet B.

Notes:

- Use the charger only in a wall outlet. Do not plug the AC adaptor into a ceiling outlet.
- If power flow to the wall outlet is controlled by a switch, make sure the switch is ON.
- Before first-time use, charge the battery for at least 18 hours.
- Never charge the battery longer than 30 hours.
- Recharge the battery for at least 14 hours after each use of your vehicle. Do not charge the battery longer than 30 hours.
- Once the battery is charged, disconnect the charger connector from the battery. Unplug the charge from the wall outlet. The battery is now ready to be installed in your vehicle. Please see the Battery installation section on page 11 for detailed simply re-connect the motor harness connector to the battery.

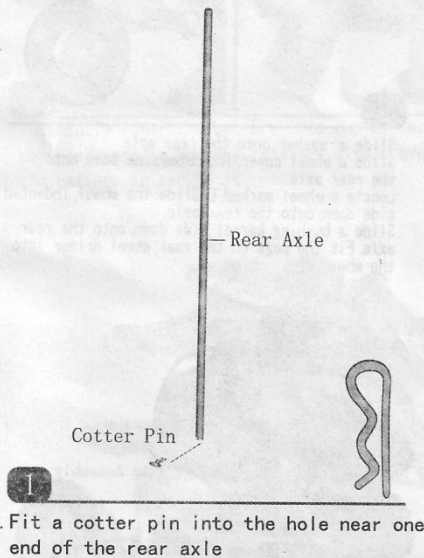

- Fit a cotter pin into the hole near one end of the rear axle

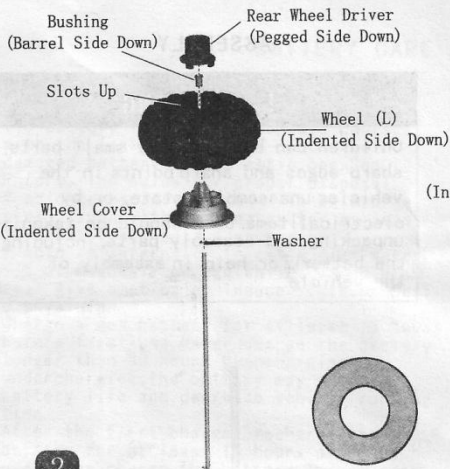

2

- . Slide a washer onto the rear axle.
- . Slide a wheel cover, indented side down, onto the rear axle.
- . Locate a wheel marked L. Slide the wheel, indented side down, onto the rear axle.
- . Slide a bushing, barrel side down, onto the rear axle. Fit the pegs on the rear wheel driver into the wheel.

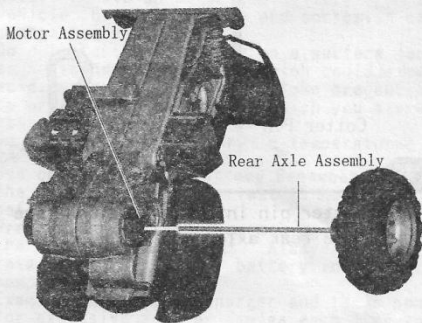

3

BOTTOM VIEW

- . Position the vehicle up side down.
- . Slide the rear axle assembly through the hole in the back end of the vehicle, as shown. Make sure the rear wheel driver fits into the pins in the motor assembly inside the vehicle.

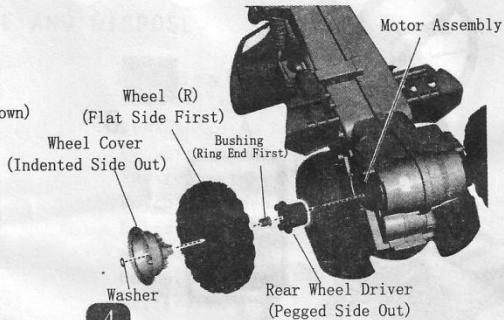

4

- . Slide a rear wheel driver, pegged side out, onto the rear axle. Make sure the rear wheel driver fits into the pins in the motor assembly inside the vehicle.
- . Slide a bushing, ring end first, onto the rear axle.
- . Locate a wheel marked R. Slide the wheel, flat side first, onto the rear axle. Make sure the pegs on the rear wheel driver fit into the slots in the wheel.
- . Slide a wheel cover, indented side out, onto the rear axle.
- . Slide washer onto the rear axle.

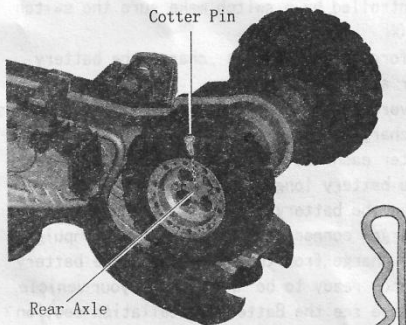

5

- . Fit a cotter pin into the hole in the rear axle.

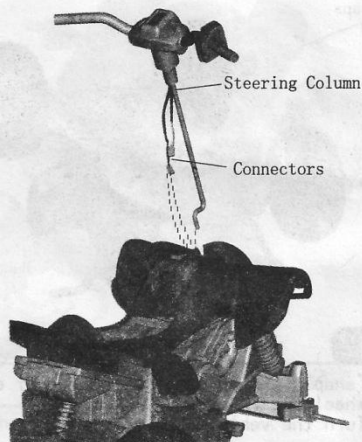

6

BACK VIEW

- . Turn the vehicle upright.
- . Fit the handlebar steering column and both connectors down through the large opening in the front end of the vehicle.



7

BOTTOM VIEW

- . Lift the front end of the vehicle up slightly. Check to be sure the steering column fits through the hole in the steering linkage.
- . Lower the front end of the vehicle.
- . Push down on the handlebar assembly to "snap" it in place.

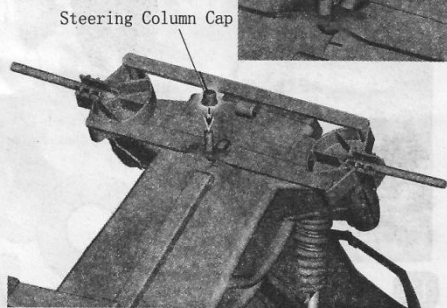

8

- . While holding the handlebar in place, carefully turn the vehicle over.
- . Again, make sure the end of the steering column is through the hole in the steering linkage.
- . Fit the steering column cap onto the end of the steering column.
- . Insert a screw through the large opening in the steering column cap and into the steering column. Tighten the screw.

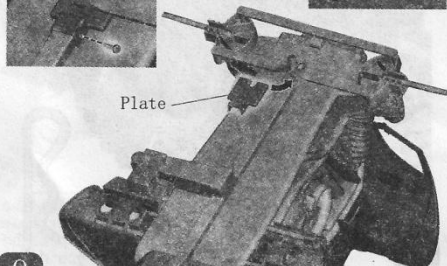

9

- . Slide the plate under the steering column, as shown.
- . Insert into the plate and tighten

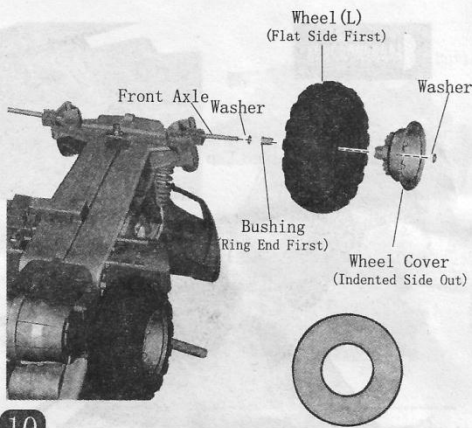

10

- . Slide a washer onto the axle.
- . Slide a bushing, ring end first, onto the front axle.
- . Locate a wheel marked L. Slide the wheel, flat side first, onto the front axle.
- . Slide a wheel cover, indented side out, onto the front axle.
- . Slide another washer on the front axle

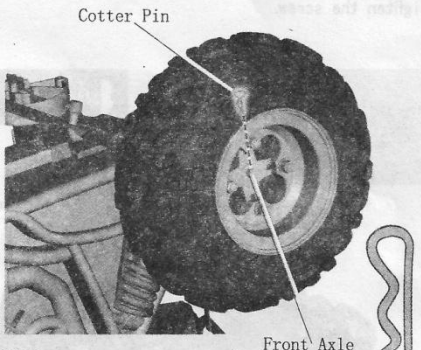

11

SIDE VIEW

- . Fit a cotter pin into the hole on the end of the front axle.
- . Repeat steps 10 and 11 to assemble the remaining washers, bushing, wheel, wheel cover and cotter pin to the other front axle.

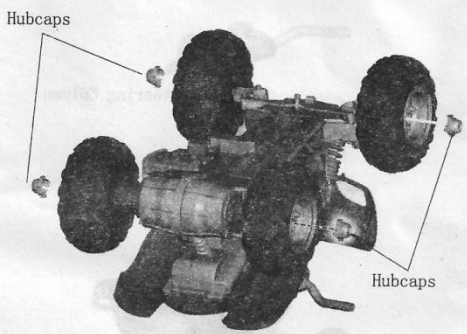

12

BOTTOM VIEW

- . "snap" a hubcap onto the center of each wheel cover.
- . Turn the vehicle upright.

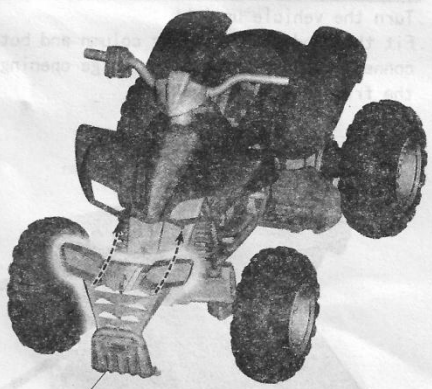

13

FRONT VIEW

- . Fit the front clip onto the front of the vehicle, as shown.
- Hint: the front clip may already be on the vehicle.

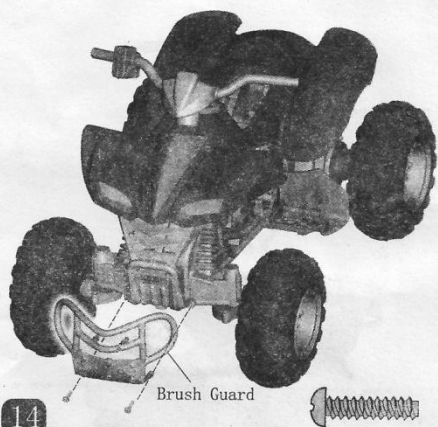

- 14
- Fit the brush guard onto the front clip.
 - Insert two screws into the lower holes in the brush guard and tighten

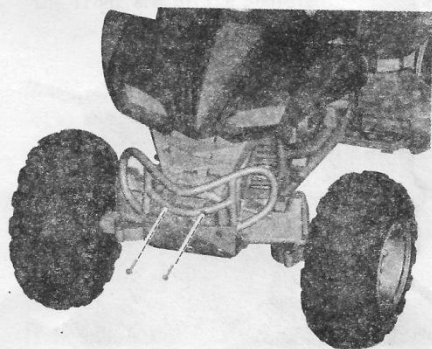

- 15
- Insert two screws into the upper holes in the brush guard and tighten,

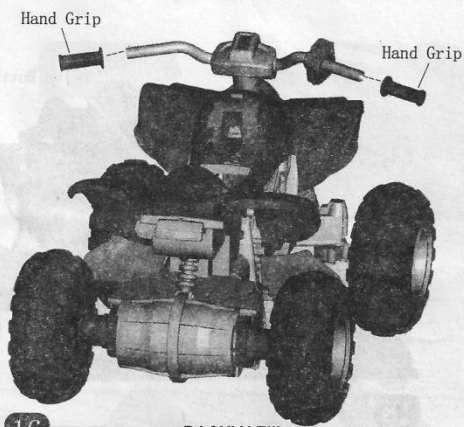

- 16 **BACKVIEW**
- Fit both hand grips on the ends of the handlebar.
- Hint: If it is difficult to slide a hand grip onto the handlebar, moisten the inside of the grip with water



Battery Indicator Connector (with red Tag)

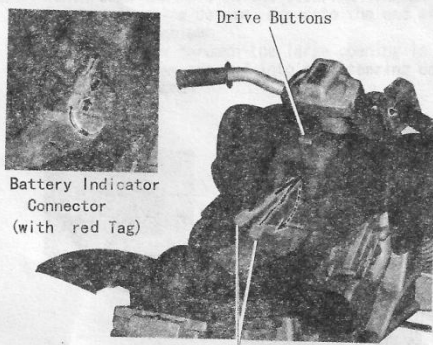

- 17
- Locate the opening under the drive buttons.
 - Reach into the opening and pull the battery indicator connector and high speed connector out through the opening.
 - Plug the battery indicator connector (with red tag) into the matching connector (with red tag). Leave the high speed connector (with black tag) unplugged for now. See page 17 for information on high speed operation.

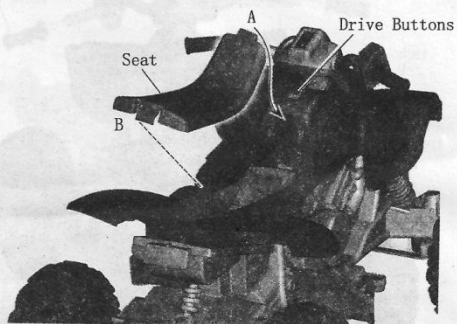

18

- .Fit the tab at the front of the seat into the slot near the drive buttons A.
- .Snap the tab at the back of the seat into the slot near the rear of the vehicle B

BATTERY INSTALLATION

IMPORTANT! Use only a 12 volt lead-acid rechargeable battery. Use of any other battery will damage your vehicle. Make sure that you charge the battery for at least 18 hours using the enclosed 12 volt charger before operating your vehicle for the first time. Charge the battery for at least 14 hours after each use of the vehicle. Never charge the battery longer than 30 hours. Failure to follow these instructions may damage your battery and will void your warranty.

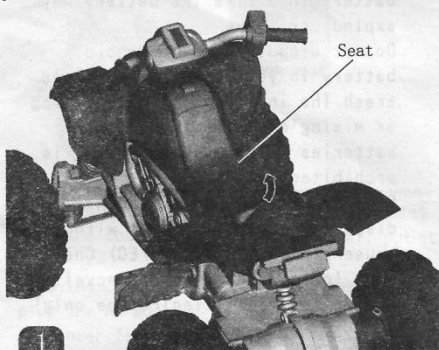

1. Press the tab under the back edge of the seat and lift to remove the seat.

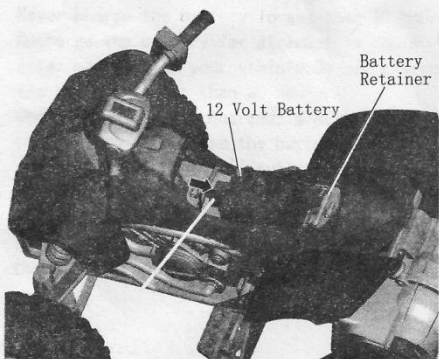

2. Lift the battery retainer to access the battery compartment. Place the battery upright in the battery compartment.

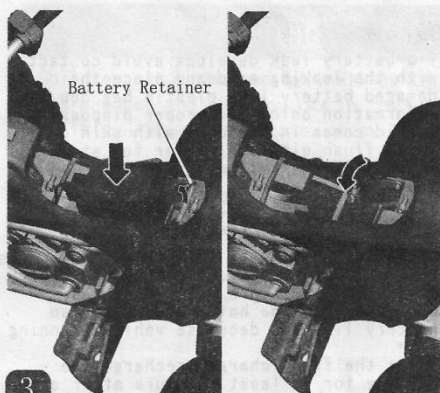

3. Carefully lower the battery into the battery compartment. The battery retainer slides over the battery to secure it.

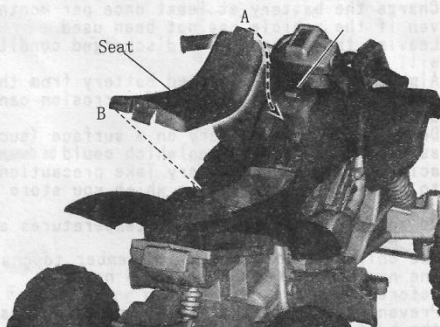

4. Fit the tab at the front of the seat into the slot near the switch A.
Snap the tab at the back of the seat into the slot near the rear of the vehicle B

BATTERY CARE AND DISPOSAL

Care

- If a battery leak develops, avoid contact with the leaking acid and place the damaged battery in a plastic bag. See information below for proper disposal.
- If acid comes in contact with skin or eyes, flush with cool water for at least 15 minutes and call a physician.
- If acid is internally ingested, give water, milk of magnesia or egg whites immediately. Never give emetics or induce vomiting. Call a physician.
- Charge a new battery for at least 18 hours before first use. Never charge the battery longer than 30 hours. Overcharging or undercharging the battery may shorten battery life and decrease vehicle running time.
- After the first charge, recharge the battery for at least 14 hours after each use. Never charge the battery longer than 30 hours. Charge the battery after each use, regardless of how long the vehicle was used. The battery must be upright while charging.
- Do not allow the battery to run down completely before charging.
- Charge the battery before storing the vehicle.
- Charge the battery at least once per month, even if the vehicle has not been used.
- Leaving the battery in a discharged condition will ruin it.
- Always remove an exhausted battery from the vehicle. Battery leakage and corrosion can damage the vehicle.
- Do not store the battery on a surface (such as a kitchen counter top) which could be damaged by the acid contained in the battery. Take precautions to protect the surface on which you store the battery.
- Do not store the battery in temperatures above 24° F or below -23° C.
- Use only a 12 volt battery. Remember to charge the new battery for at least 18 hours before first use.
- Prevent the battery from moving freely inside the battery compartment. Always use the battery retainer to secure the battery in the battery compartment.
- Examine the battery, charger and their connectors for excessive wear or damage each time you charge the battery. If damage is detected, do not use the charger or the battery until you have replaced the worn or damaged part.

Disposal

- Your battery is a non-spillable, sealed-acid battery. It must be recycled or disposed of in an environmentally sound manner.
- Do not dispose of a lead-acid battery in a fire. The battery may explode or leak.
- Do not dispose of a Lead-acid battery in your regular household trash. The incineration, landfilling or mixing of sealed Lead-acid batteries with household trash is prohibited by law in most areas.
- Protect the environment by not disposing of this product with household waste (2002/96/EC). Check your local authority for recycling advice and facilities (Europe only).

SAFE DRIVING RULES

RIDING HAZARD



WARNING

- Prevent Injuries and Deaths
- Direct Adult Supervision Required.
- Never Ride at Night.
- Keep Children Within Safe Riding Areas.

These areas must be:
-away from swimming pools and other bodies of water to prevent drownings
-generally level to prevent tipovers
-away from steps, steep inclines, cars, roads and alleys.

Riding Rules

Make sure children know and follow these rules for safe driving and riding.

- Always sit on the seat.
- Always wear shoes.
- Only 1(one) rider at a time

Teach safety Rules to Children

While children can quickly develop the skill necessary to drive this vehicle, it is important to remember that their judgment skills are still very immature. Unsupervised driving by children can lead to serious injury. Before children use this vehicle, an adult should carefully evaluate the driving area as well as the children's skill level and ability to drive this vehicle safely. Children are not always able to recognize or anticipate hazards, even when they have been taught about them. There is no acceptable substitute for direct adult supervision. Teach appropriate safety rules to your child before allowing operation of this vehicle. These rules should also be reviewed with neighborhood children or other playmates who want to drive this vehicle.

Riding Rules

Make sure children know and follow these rules for safe driving:

1. Always sit on the seat.
2. Always wear shoes.
3. Only 1(one) rider at a time. A child who is not sitting on the seat or who is standing on the vehicle, could fall off, cause a tip-over or block the driver's view. A child could be seriously injured.
4. Do not allow any child to drive the vehicle in the street or near moving (motorized) vehicles.
5. Do not allow any child to drive near bodies of water (such as pools or creeks), obstructions (such as furniture, low tree limbs or play equipment), or drop-offs (such as stairs or decks).
6. Do not allow any child to drive the vehicle in the dark. A child could encounter unexpected obstacles and have an accident. Operate the vehicle only in the daytime or a well-lit area.
7. Restrict your child's driving to areas that are generally level with gentle inclines or slopes.
8. Do not allow your child to drive down or across a steep slope.
 - The vehicle may gain unsafe speed, even if the pedal is released to stop.
 - The vehicle may tilt and tip over.
 - The wheels could lose traction, causing the vehicle to slip.
9. Do not allow your child to drive up steep inclines. The motor may stop and the vehicle could roll backwards at an unsafe speed.
10. Never put anything near any moving parts. Rotating parts such as motors, gear boxes and wheels can snag fingers, hair, etc., causing serious injury. Do not allow operation of the vehicle when it is on its side or in an upside-down position.
11. Do not operate the vehicle near flammable vapors (gasoline, paint thinner, acetone, liquid wax, etc.) The vehicle's electrical switches, like most electrical switches, emit an internal spark when first turned on or turned off. The presence of flammable liquids or vapors could cause an explosion or a fire. Keep all flammable products in tightly sealed containers and away from the vehicle.
12. Do not allow a child to operate the vehicle without direct adult supervision. To prevent unsupervised use of the vehicle, disconnect the motor harness from the battery when the vehicle is not in use.

To disconnect the motor harness:

- press the rear tab on seat and lift to remove.
- Lift the battery retainer and slowly lower the battery into the compartment.
- Replace the seat on the vehicle.
- Lift the battery retainer to access the battery compartment
- Pull the connector from the battery.

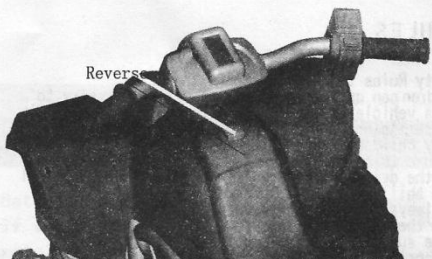

- IMPORTANT!** To prevent damaging the motors and gears, teach your child to stop the vehicle before switching direction.
- Press the REVERSE button on the tank.
- Press the foot pedal. The vehicle backs up at a maximum of 7.5km/h
- Help your child practice steering to learn how quickly to turn the handlebar when driving in reverse.



- Your vehicle has a patented electronic braking system that automatically stops the vehicle when your child's foot lifts from the pedal.
- Make sure your child's comfortable with steering the vehicle and automatically knows how to stop.

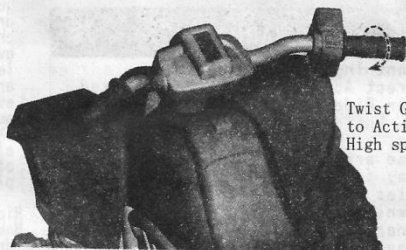

- Turn the right grip to shift the vehicle into high speed. The vehicle drives forward at a maximum of 7.5km/h.
- Help your child practice steering to learn how far and how quickly to turn the handlebar when driving forward in high speed.
- IMPORTANT!** Use the vehicle ONLY outdoors. Most interior flooring can be damaged by riding the vehicle indoors. Will not be responsible for damaged to floors if vehicle is used outdoors.

VEHICLE CARE

Check all screws, cap nuts and their protective coverings regularly and tighten as required. Check plastic parts on a regular basis for cracks or broken pieces.

During snowy or rainy weather, the vehicle should be stored inside or under a protective cover. Remember to charge the battery at least once per month while your vehicle is not in regular use.

An extremely dirty vehicle can be rinsed with a hose but avoid spraying directly into switches motors and battery compartment.

Water or moisture in the motors or electrical switches can cause them to corrode, and could cause switch or motor failure.

Avoid operating the vehicle on sand. Sand in the motors or electrical switches can cause them to jam, and could cause switch or motor failure.

The vehicle can be wiped down with a soft, dry cloth. For a shiny finish, you can wipe plastic parts with a non-wax furniture polish applied to a soft-cloth. DO not use automotive wax.

To ensure that your vehicle stays in good operating order, we recommend that you periodically have your vehicle checked by a authorized service center. For the location of the authorized service center nearest you.

PROBLEMS AND SOLUTIONS

PROBLEM	POSSIBLE CAUSE	SOLUTION
<p>Vehicle does not run</p>	<p>Undercharged battery</p>	<p>Charge the battery. A new battery should have been charged for at least 18 hours before using the vehicle for the first time. After first-time use, recharge the battery for at least 14 hours after each use. Never charge the battery longer than 30 hours.</p> <p>Check all connectors. Make sure the charger connector is plugged into the battery, and that the charger is plugged into the wall.</p> <p>Make sure power flow to the wall outlet is "ON".</p>
	<p>Charger is not working</p>	<p>There is no sure way to tell if your charger is working unless you have a volt meter. If you suspect there is a problem with your charger contact authorized service center. They can test your charger for you.</p>
	<p>Tripped thermal fuse</p>	<p>The built-in thermal fuse may "trip" and shut down operation of the vehicle if the vehicle is overloaded or the driving conditions too severe. Once a fuse has "tripped", remove your foot from the pedal and wait approximately 25 seconds before operating the vehicle again. To avoid repeated automatic shutdowns, do not overload the vehicle by exceeding the 40kg maximum weight capacity or by towing anything behind the vehicle. Do not drive up hills or run into fixed objects, which can cause the wheels to stop spinning while power is still being supplied to the motors, if a thermal fuse continually trips, contact service center.</p>
	<p>Loose wire or loose connectors</p>	<p>Check all wires and connectors. Make sure the motor harness connector is plugged into the battery, and that there are no loose wires around motors</p>
	<p>Dead battery</p>	<p>If your battery is old or if you have not followed Battery Care instructions, your battery may be dead, you can have it tested at service center</p>
	<p>Electrical switch damage</p>	<p>The electrical switches can become corroded due to exposure to water or moisture, or can jam due to loose dirt, sand or gravel.</p>
<p>Vehicle was running but suddenly stopped</p>	<p>Motor damage</p>	<p>Contact your local service center for diagnosis and repair.</p>
	<p>Loose wire or loose connectors</p>	<p>Check all wire and connectors. Make sure the motor harness connector is plugged into the battery, and that there are no loose wires around the motors.</p> <p>The built-in thermal fuse may "trip" and shut down operation of the vehicle if the vehicle is overloaded or the driving conditions too severe. Once a fuse has "tripped", remove your foot from the pedal and wait approximately 25 seconds before operating the vehicle again.</p>

PROBLEM	POSSIBLE CAUSE	SOLUTION
Short run time (Less than 1-3 hours per charge)	Undercharged battery	Charge the battery. A new battery should have been charged for at least 18 hours before using the vehicle for the first time. After first-time use, recharge the battery for at least 14 hours after each use. Never charge the battery longer than 30 hours.
		Check all connectors. Make sure the charger connector is plugged into the battery, and that the charger is plugged into the wall.
		Make sure power flow to the wall outlet is "ON".
	Overcharged battery	Do not charge the battery longer than 30 hours. If you suspect that your battery is damaged as a result of overcharging, contact service center. They can test your battery for you.
	Battery is old will not accept full charge	Even with proper care, a rechargeable battery does not last forever. Average battery life is 1 to 3 years depending on vehicle use and use conditions. Replace the battery with a new 12 volt rechargeable battery. Do not substitute parts.
Vehicle runs sluggish	Undercharged battery	Charge the battery. A new battery should have been charged for at least 18 hours before using the vehicle for the first time. After first-time use, recharge the battery for at least 14 hours after each use. Never charge the battery longer than 30 hours.
		Check all connectors. Make sure the charger connector is plugged into the battery, and that the charger is plugged into the wall.
		Make sure power flow to the wall outlet is "ON".
	Battery needs charging	Be sure to charge the battery after each use.
	Battery is old and will not accept full charge	Even with proper care, a rechargeable battery does not last forever. Average battery life is 1 to 3 years depending on the vehicle use and use conditions. Replace the battery with a new 12 volt rechargeable battery. Do not substitute parts.
Vehicle is overloaded	Make sure you do not overload the vehicle by allowing more than one rider at one time, by exceeding the 40kg maximum weight capacity, or by towing objects behind the vehicle.	
Driving conditions are too stressful	Restrict your child's driving to areas that are generally level with gentle inclines or slopes.	

PROBLEM	POSSIBLE CAUSE	SOLUTION
Vehicle runs in low speed, but does not run in high speed. Please note: The vehicle is designed to operate in low speed only in reverse.	High speed hook-up not disconnected	The vehicle was pre-set to run only in low speed. To allow the vehicle to run in low and high speed, you must connect the High Speed connectors. Follow the instructions on page 18. Note: The high speed connectors must be joined to use the high speed grip.
When the foot pedal is pressed one rear wheel spins.	Operation of vehicle in low speed	It is possible that only one rear wheel may spin when both rear wheels are raised off the ground and the vehicle is in low speed. This does not necessarily indicate a problem. Check for proper operation of the drive system by raising the rear wheels off the ground and pressing the foot pedal. If only one rear wheel spins, carefully press your hand on the spinning wheel to slow it down. The other rear wheel should begin to spin. If the other rear wheel does not begin to spin, there may be a problem with the vehicle. Contact service center for diagnosis and repair.
Sometimes the vehicle doesn't run, but other times it does	Loose wire or connector	Check all wires around the motors and all connectors to make sure they are tight.
	Motor or electrical switch damage	Contact service center for diagnosis and repair.
When the foot pedal is pressed, the vehicle won't run without a push	Loose wire or connector	Check all wires around the motors and all connectors to make sure they are tight.
	"Dead Spot" on motor	Contact service center for diagnosis and repair
Battery's thermal fuse constantly trips, but the vehicle is not overloaded nor the driving conditions too severe	Damaged battery	Contact service center for diagnosis and repair
	Child is switching between FORWARD and REVERSE without stopping	Teach your child to stop the vehicle before switching direction.
Loud clacking or grinding noise from a motor-gearbox	Broken gears	Contact service center for diagnosis and repair.
Charger gets warm during use	It is normal for some chargers to get warm during use and is not reason for concern	No action required.
		If your charger does not get warm during use, it does not mean that it is not working properly.
Battery makes a sizzling or gurgling noise when charging	It is normal for some batteries to make noise and swell slightly while charging and is not reason for concern	No action required
		If your battery does not make noise or swell slightly during charging, it does not mean that it is not working properly

Please keep this manual properly

NOTE

1. All photos in this manual are used to specify the operation and construction of the product, When you find some differences between the product and the photo, please follow the product.
2. We won't notify you when we modify the construction and appearance of the product partially in order to improve the product quality.